

Luminaire traditionnels

Antique style luminaires

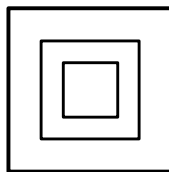
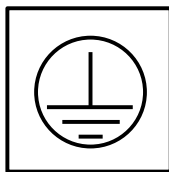
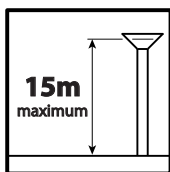
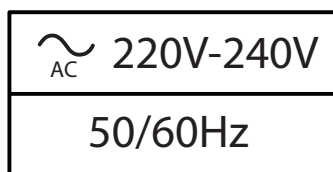

Position de fonctionnement: Verticale Operating position: Vertical

Si le câble extérieur, la source lumineuse ou le driver contenu dans ce luminaire sont endommagés, ils doivent être exclusivement remplacés par le fabricant ou son agent de maintenance ou une personne de qualification équivalente, cela afin d'éviter tout risque

If the external cable, lighting source or driver contained in this light are damaged, they have to be replaced by the manufacturer or its maintenance agent or an equally qualified worker, in order to avoid any risk

Luminaire concernés

Related luminaires

Cap Ferrat



Eze



Mandelieu



Mougins



Opio



Ramatuelle



St Paul



Sophia



St Jeannet



Valbonne



Vence



	Cap Ferrat 640	Cap Ferrat 650	Eze 31	Eze 650	Mandelieu 640	Mandelieu 650	Mougins 640	Mougins 650	Mougins 660
pois (kg) / weight	8,0	9,0	6,5	11	11,0	14,0	10,0	12,0	15,0
scx (m ²) / cxs	0,12	0,17	0,09	0,17	0,10	0,13	0,10	0,17	0,20
longueur (a) / lenght									
diamètre (a) / diameter	480	580	310	500	400	500	430	580	620
hauteur(b) / height	700	810	610	880	770	880	720	800	850
largeur (c) / width									

	Opio 640 portée	Opio 640 suspendue	Opio 650 portée	Opio 650 suspendue	Ramatuelle 638	Ramatuelle 648
pois (kg) / weight	9,0	9,0	10,0	10,0	8,4	10,0
scx (m ²) / cxs	0,11	0,11	0,16	0,16	0,12	0,16
longueur (a) / lenght						
diamètre (a) / diameter	490	490	580	580	480	580
hauteur(b) / height	590	820	730	940	760	850
largeur (c) / width						

	Sophia 638	Sophia 642	St-jeannet 640	St-jeannet 650	St-jeannet 660	St-paul 640	St-paul 650
pois (kg) / weight	8,0	8,2	8,4	10,5	12,6	9,0	11,0
scx (m ²) / cxs	0,14	0,17	0,12	0,19	0,23	0,17	0,23
longueur (a) / lenght	380	420					
diamètre (a) / diameter			430	570	620	430	570
hauteur(b) / height	800	840	760	870	900	830	910
largeur (c) / width							

	Valbonne 640	Valbonne 650	Valbonne 665	Vence 634	Vence 638	Vence 638 verre plat	Vence 642	Vence 642 verre plat	Vence 645	Vence 645 verre plat
pois (kg) / weight	10,0	12,0	15,0	6,5	8,4	8,4	8,7	8,7	9,5	9,5
scx (m ²) / cxs	0,10	0,17	0,20	0,15	0,17	0,09	0,19	0,10	0,21	0,11
longueur (a) / lenght				340	380	380	420	420	450	450
diamètre (a) / diameter	430	580	620							
hauteur(b) / height	720	800	850	720	850	850	870	870	910	910
largeur (c) / width										

Poids indiqués sans appareillage
Indicated weight are without control gear

Ouverture
Opening

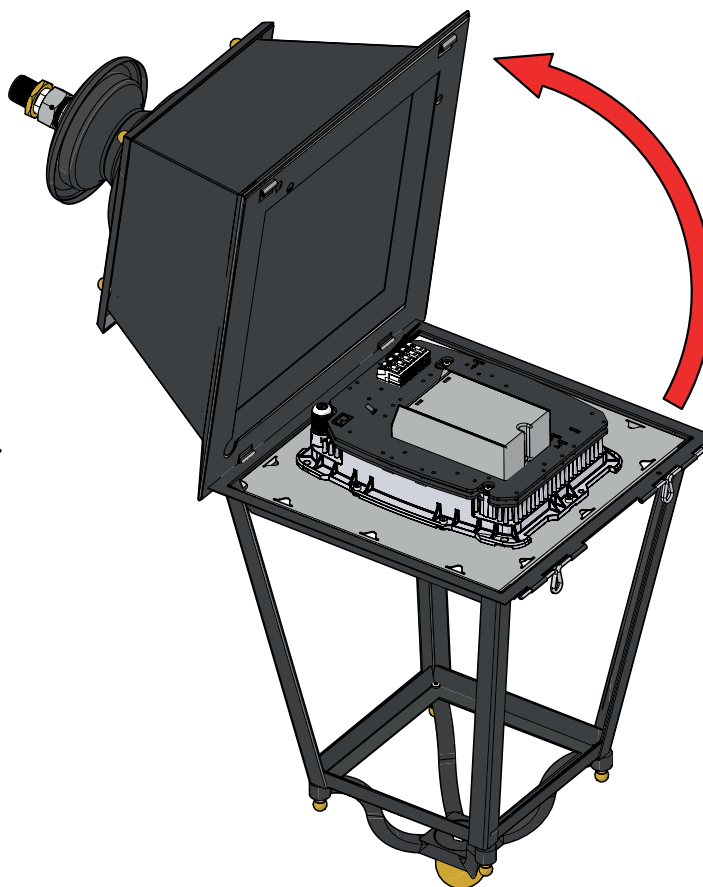
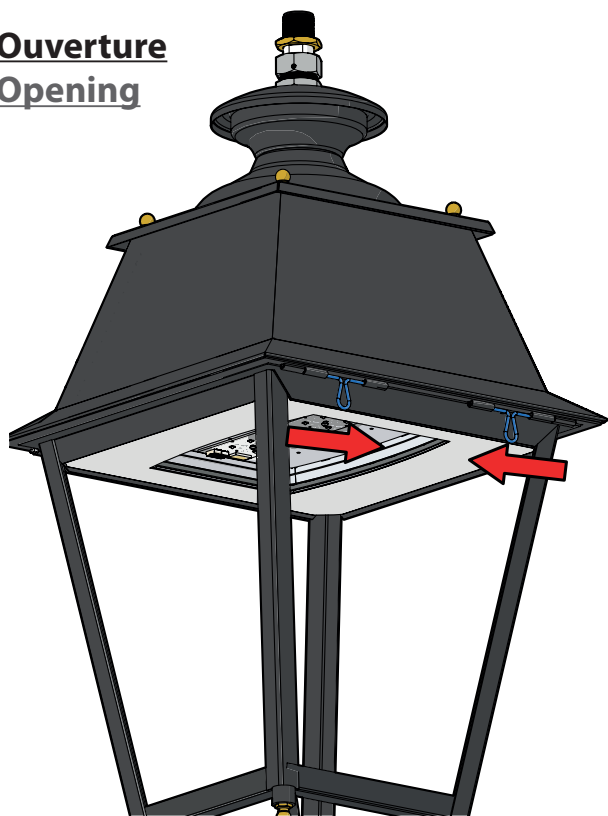

Version luminaire porté
Top luminaire version

1

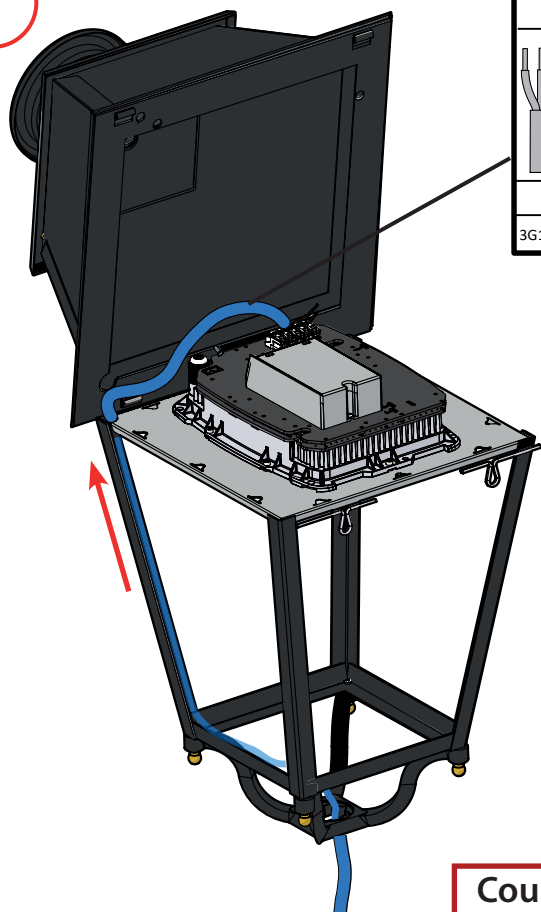

CI I	CI II
10mm 35mm	
HO7 RNF	
3G1,5 mm ²	2x1,5 mm ²

2

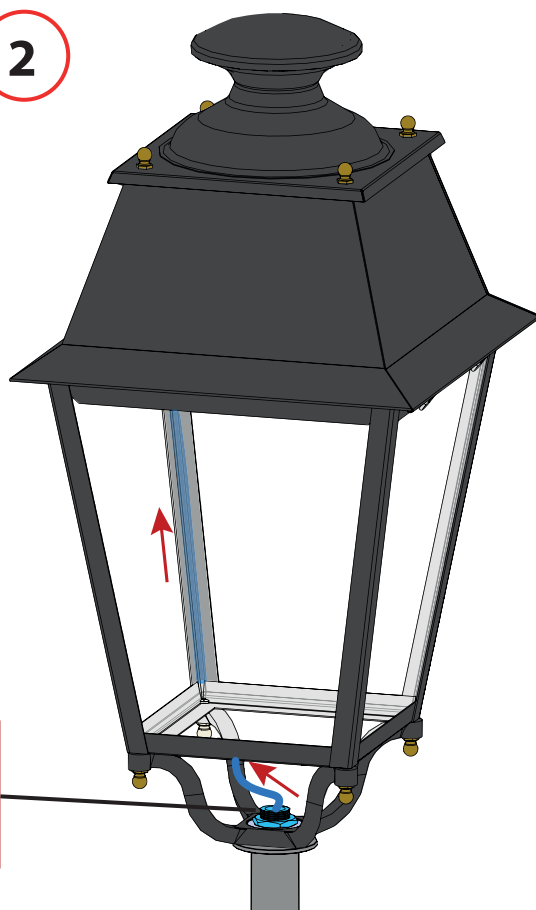

Ø 32 Maxi
Couple de serrage
Tightening torque
32 N.m

Version luminaire suspendu
Top hanging luminaire version

1

Monter le raccord sur la crose
 Mount the connector on the bracket



Frein filet-Thread lock
 Loctite 271
 Orapi 300

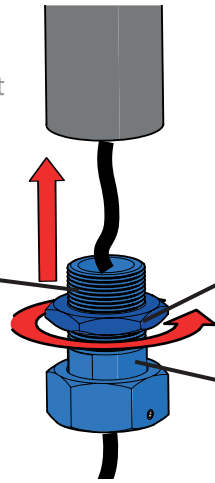

36



3

24

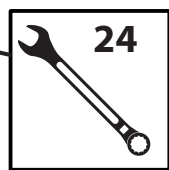

Couple de serrage
Tightening torque
32 N.m

2



Ne pas faire tourner le luminaire lors du serrage
au risque de créer une entrée d'eau
 Don't rotate the luminaire when tightening as
 this may cause water ingress

Frein filet-Thread lock
 Loctite 271
 Orapi 300

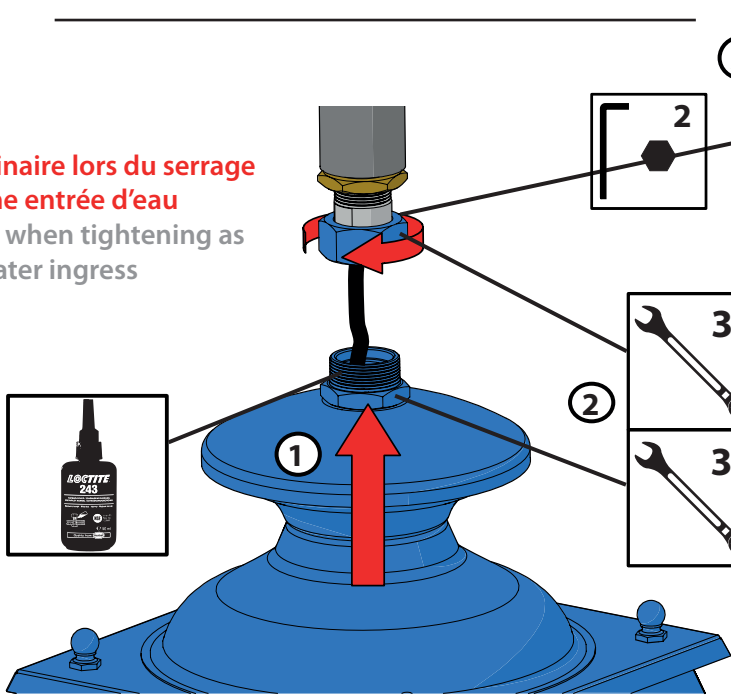

36

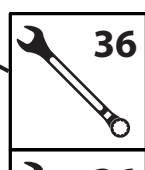

Serrage
Tighten

36

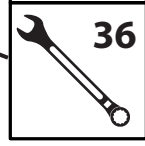

Maintenir lors du serrage
Hold when tightening

Couple de serrage
Tightening torque
32 N.m

3

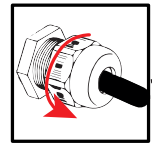

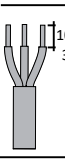
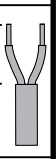
CI I	CI II
	
10mm	35mm
HO7 RNF	
3G1,5 mm ²	2x1,5 mm ²

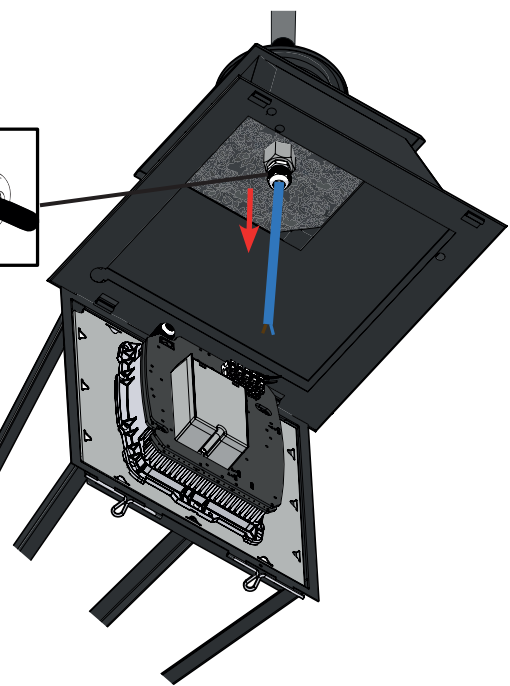

4

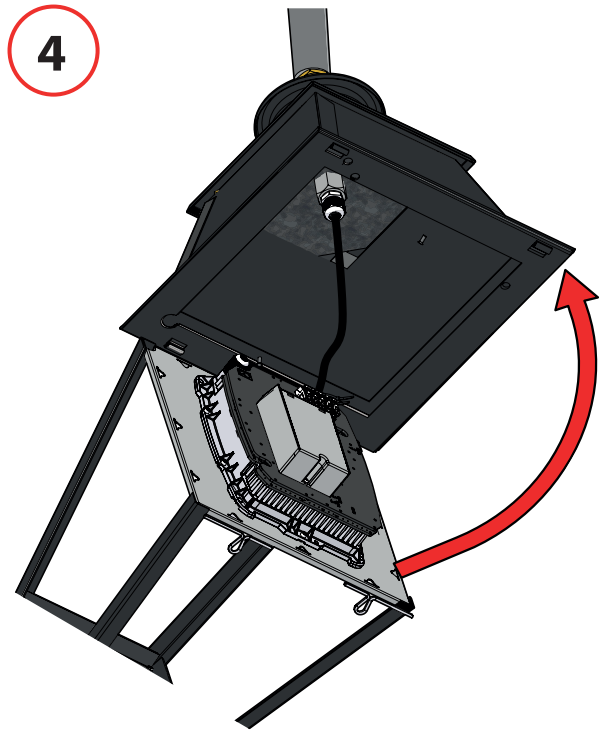

Maintenance

1

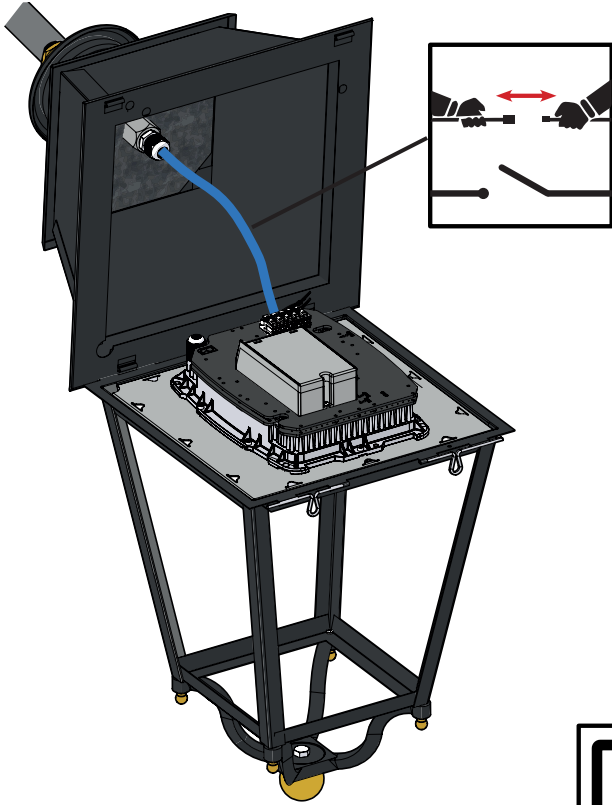

2

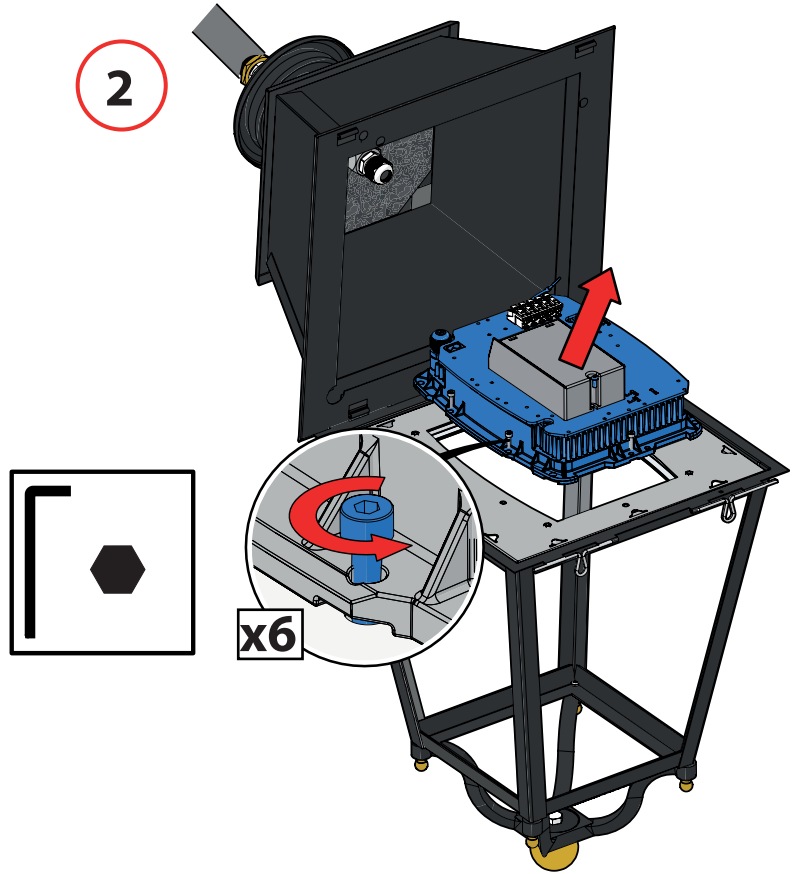

Nettoyage protection Protection cleaning

