

# Aro



AC 220V-240V  
50/60Hz

15m  
maximum



Position de fonctionnement: Horizontale

Operating position: Horizontal

	Aro S		Aro M	
	Sur manchon On sleeve	Sur lyre On yoke	Sur manchon On sleeve	Sur lyre On yoke
A (mm)	Ø480	Ø480	Ø580	Ø580
B (mm)	683	516	778	614
C (mm)	99	743	104	747
Masse (kg) Weight	8.5	9.5	13.4	14.4
ScX (m <sup>2</sup> ) CxS	0.028	0.039	0.031	0.042

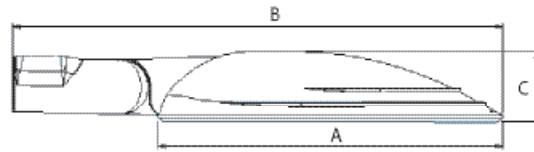

Si le câble extérieur, la source lumineuse ou le driver contenus dans ce luminaire sont endommagés, ils doivent être exclusivement remplacés par le fabricant, son agent de maintenance ou une personne de qualification équivalente, cela afin d'éviter tout risque.

If the external cable, light source or driver contained in this light are damaged, they have to be exclusively replaced by the manufacturer, his maintenance agent or an equally qualified worker, in order to avoid any risk.

## Montage

1

Pincer les pattes pour ouvrir  
Pinch fixing clip to open

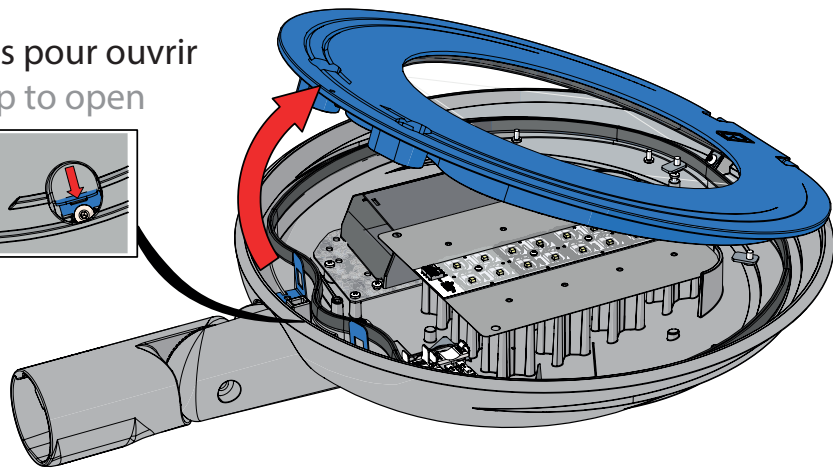
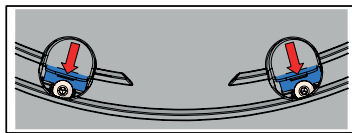

2

Standard

2

CI I		CI II	
9mm		40mm	
HO7 RNF			
3G1,5 mm <sup>2</sup>	5G1,5 mm <sup>2</sup>	2x1,5 mm <sup>2</sup>	4x1,5 mm <sup>2</sup>

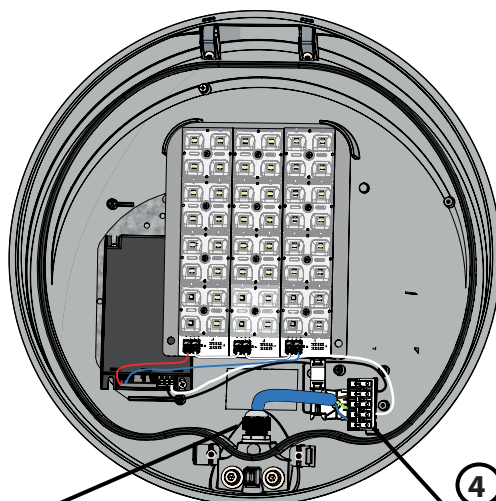

En option / Optional

Ou  
Or

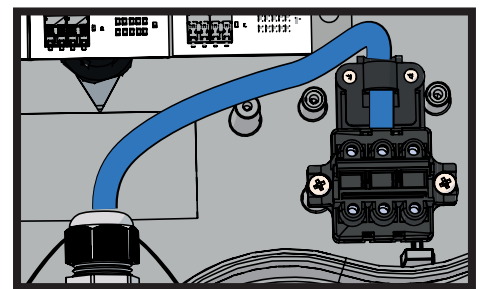

3

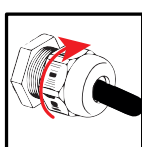

1

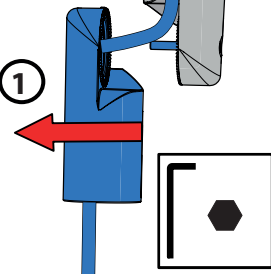

4

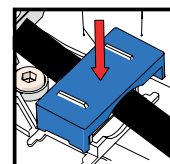
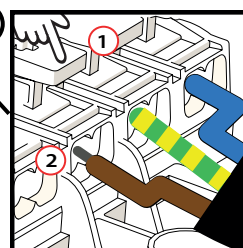

Câblage / Cabling

3

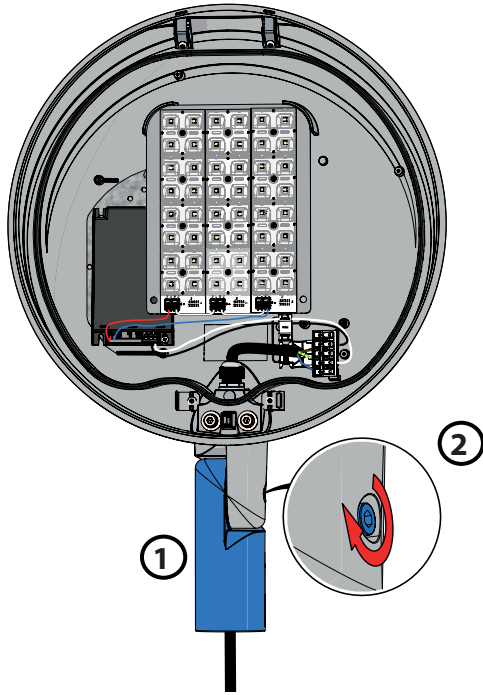

4

Fermeture sans outil  
Closing without tool

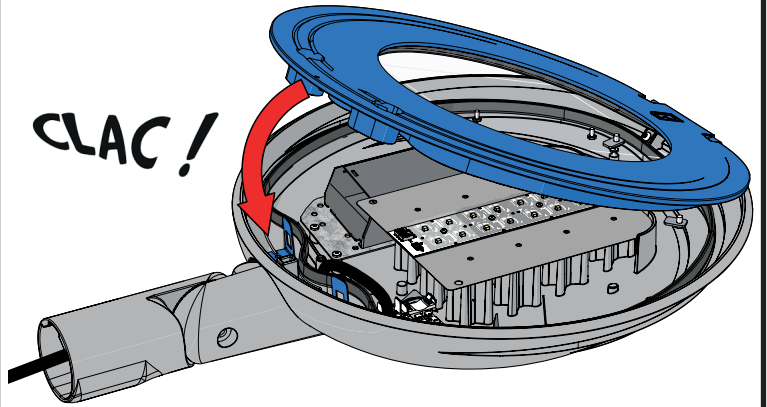

### Inclinaison / Tilt

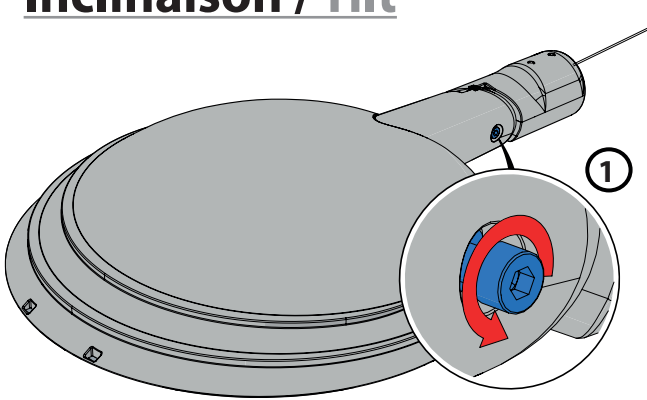

Ø34\*, 42\*, 48\* ou 60mm  
\*Avec cale reductrice  
\*With reductive wedge

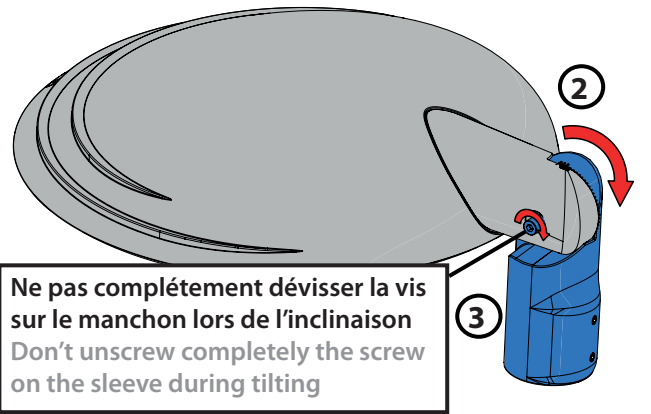
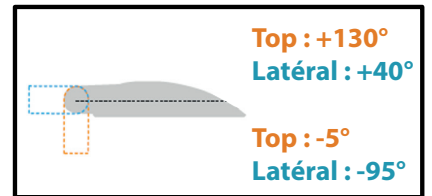

Ne pas complètement dévisser la vis sur le manchon lors de l'inclinaison  
Don't unscrew completely the screw on the sleeve during tilting

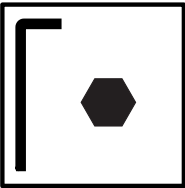

Couple de serrage  
Tightening torque  
6 N.m

### Installation

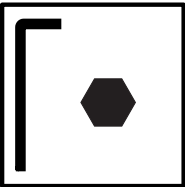

Couple de serrage  
Tightening torque  
6 N.m

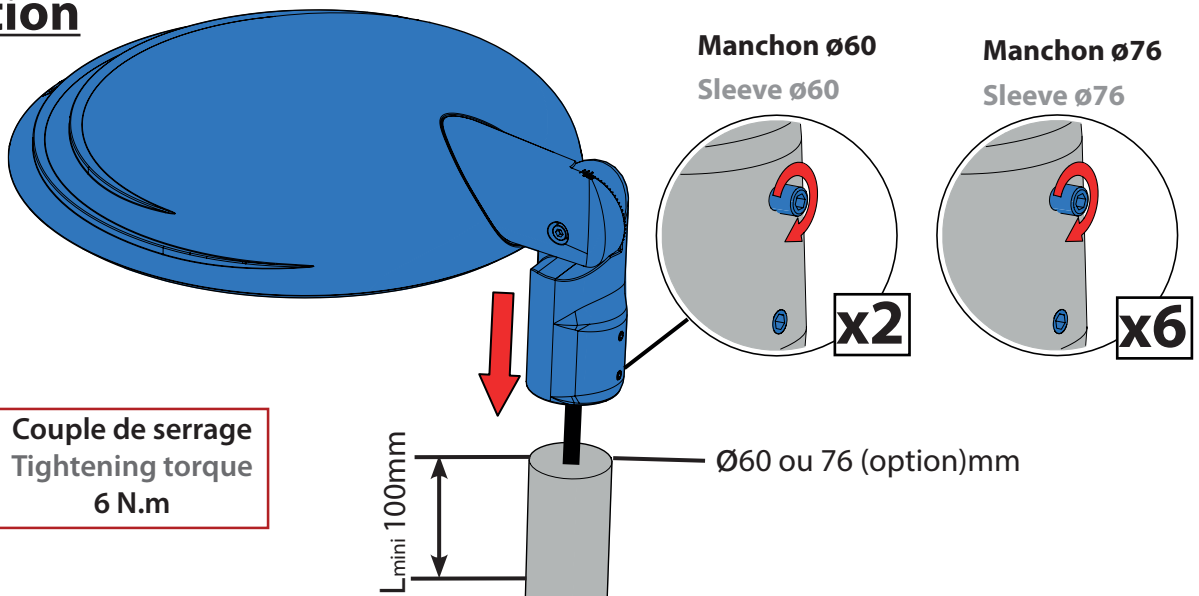

# Lyre

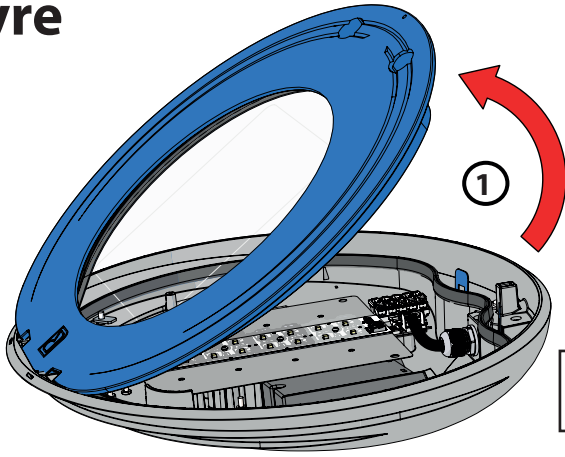

Pincer les pattes pour ouvrir  
Pinch fixing clip to open

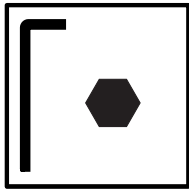

Couple de serrage  
Tightening torque  
15 N.m

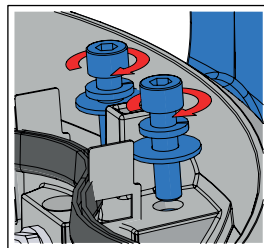

③

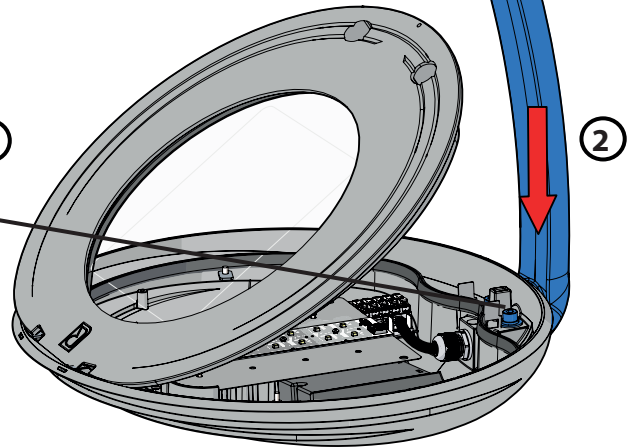

②

④ Refermer le luminaire comme sur la vue n°4  
Close the luminaire as shown in view 4

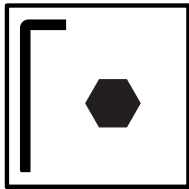
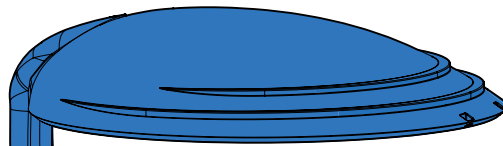

Couple de serrage  
Tightening torque  
6 N.m

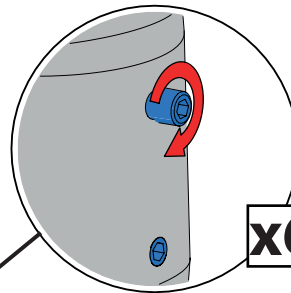

x6

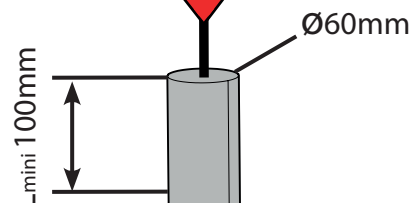

# Maintenance

1

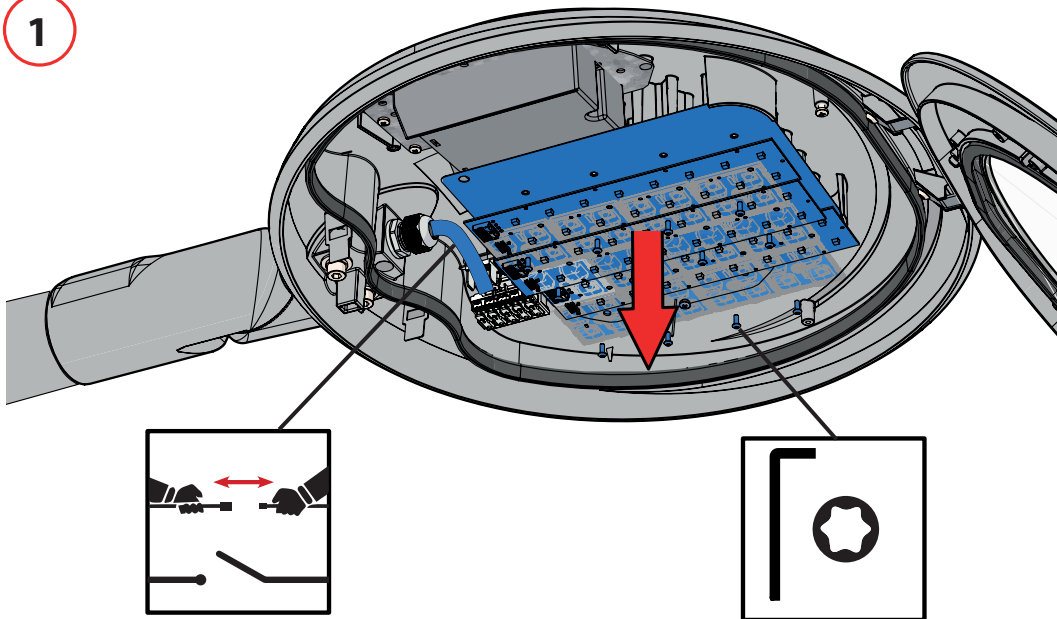

2

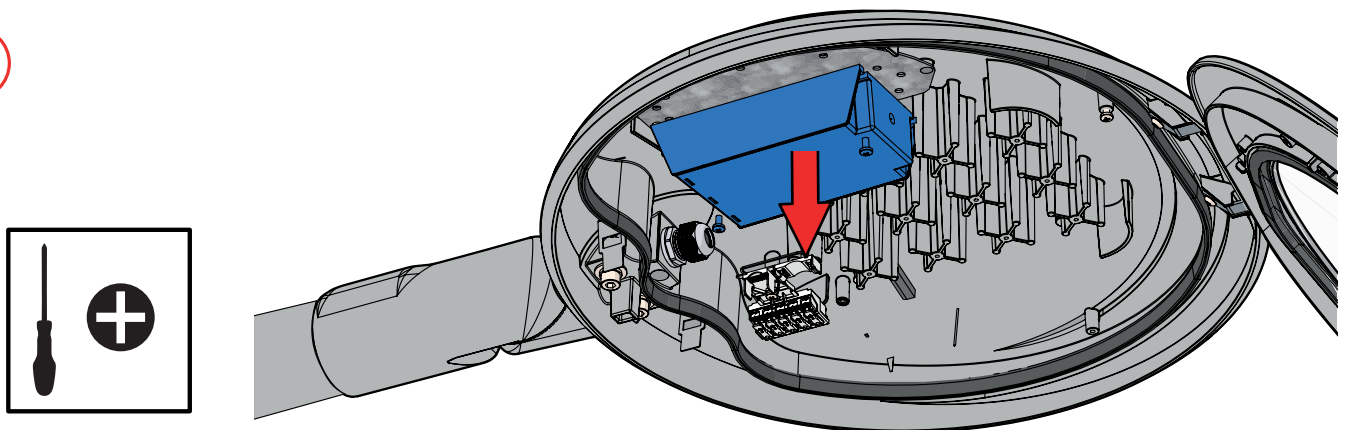

# Nettoyage / Cleaning

