

# FESTALED INSTALLATION & MAINTENANCE



RAGNI

## PROCEDURE D'INSTALLATION INSTALLATION PROCEDURE

1

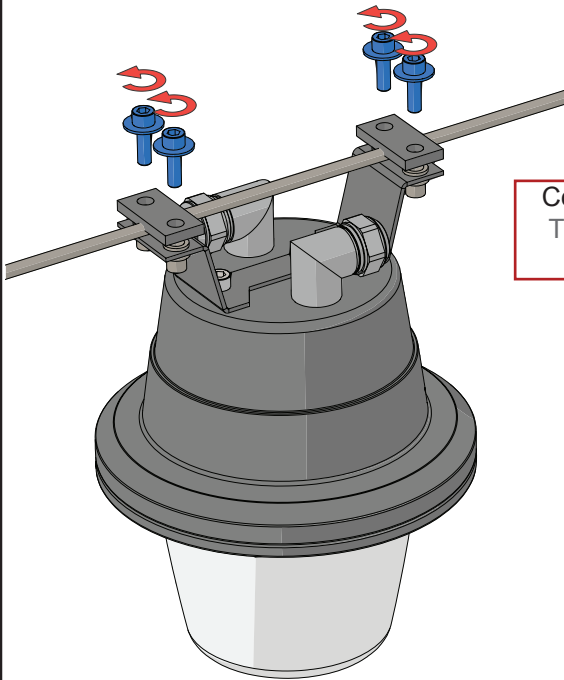

**Couple de serrage**  
Tightening torque  
15 Nm

**ATTENTION / WARNING**

**DIAMETRE DE FILIN ADMISSIBLE**  
**HANGING CABLE DIAMETER CAPACITY**  
Le luminaire est conçu pour s'accrocher à un filin de Ø8mm MAX.  
The luminaire is designed to be hung to Ø8mm cable MAX.

2

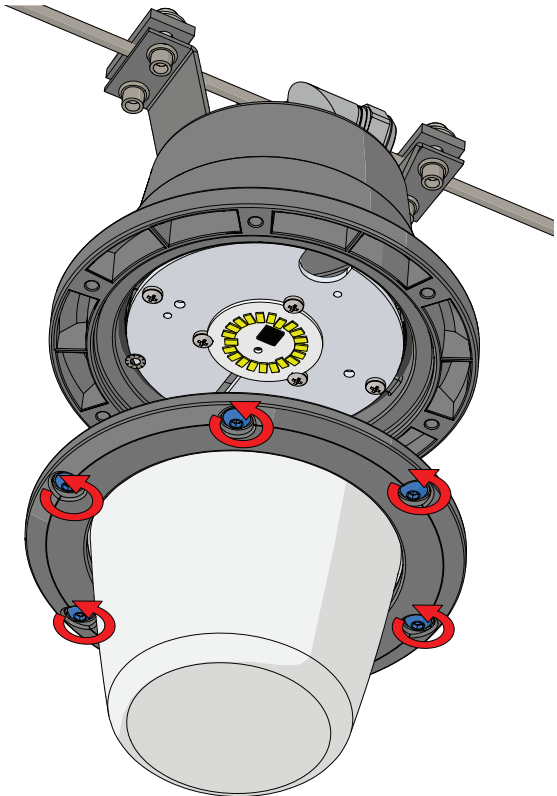
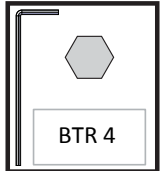

3

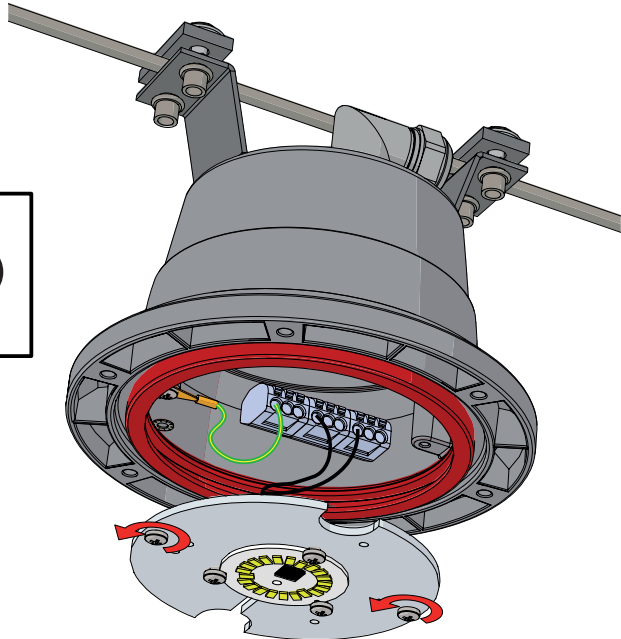
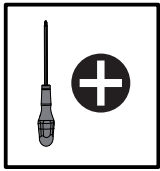

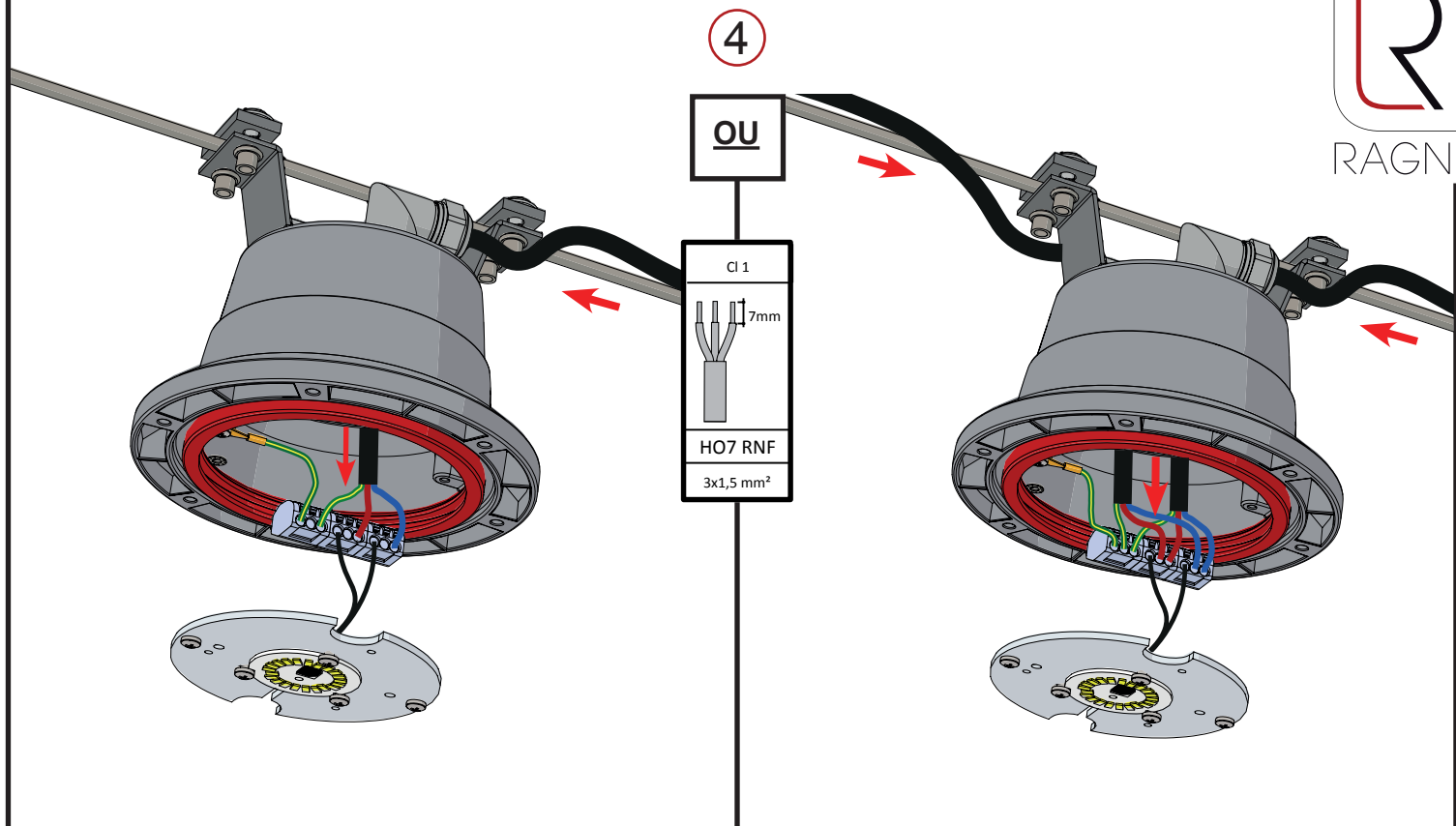

**⚠ ATTENTION / WARNING**

**DIAMETRE DE CABLE D'ALIMENTATION ADMISSIBLE**  
**POWER SUPPLY CABLE DIAMETER CAPACITY**  
 Le luminaire est conçu pour être alimenté par des cables de Ø6mm à 12mm MAX  
 The luminaire is designed to be powered with Ø6mm to 12mm MAX power supply cable.

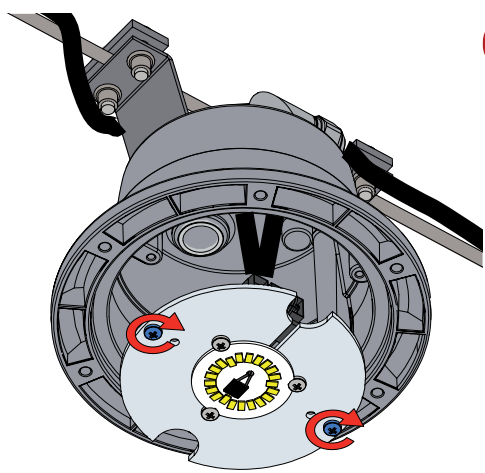

5

Serrage en croix  
 Crosswise tightening

Couple de serrage  
 Tightening torque  
 5 Nm

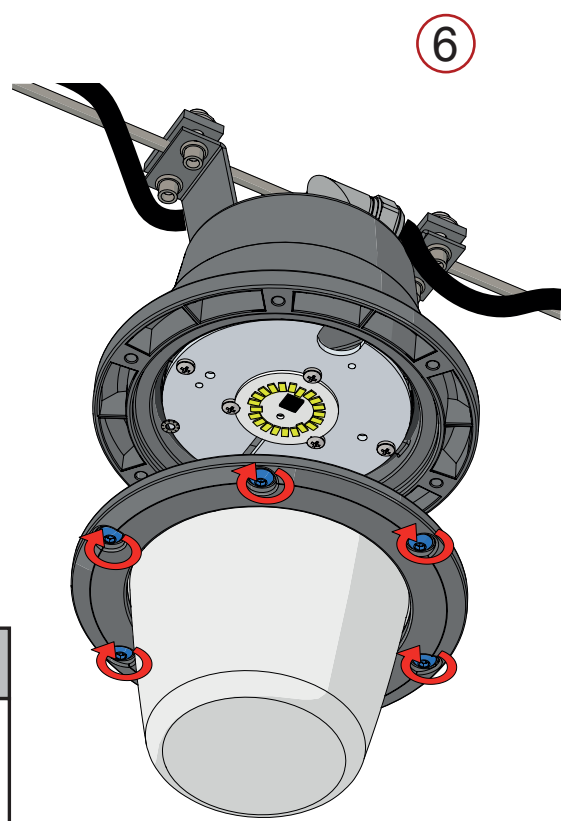

6

**⚠ ATTENTION / WARNING**

**RISQUE DE DEFAUT D'ETANCHEITE**  
**WATERTIGHTNESS FAILURE RISK**  
 Le non respect des consignes de serrage peut avoir pour conséquence la déformation de la bague de serrage.  
 Non respect of the tightening instructions may result in the tightening ring distortion and therefore watertightness failure.

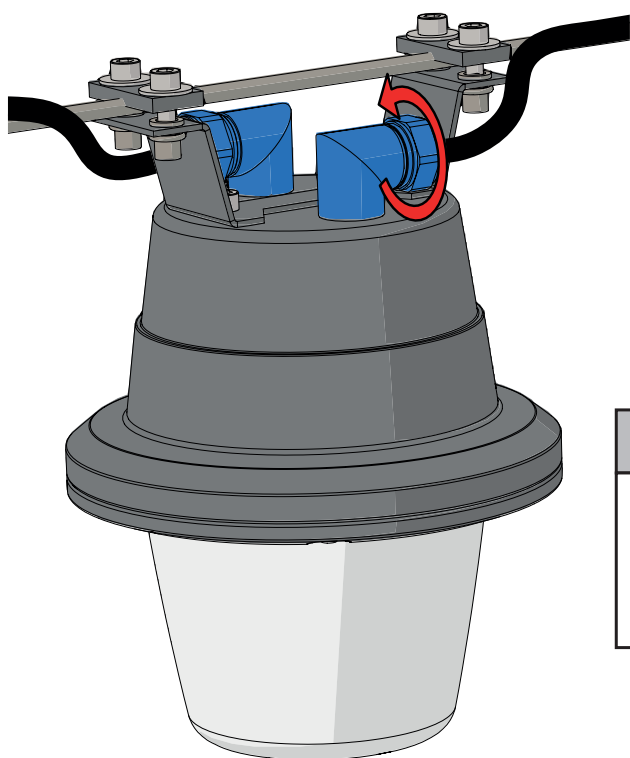

7

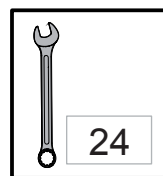

Couple de serrage  
Tightening torque  
4,5 Nm

**! ATTENTION / WARNING**

**RISQUE DE DEFAUT D'ETANCHEITE AU SERRAGE**  
**WATERTIGHTENING FAILURE RISK WHEN TIGHTENING**  
 Maintenir la base des presses étoupes au serrage de leurs têtes.  
 Maintain still the cable glands bases when tightening their heads.

## CARACTERISTIQUES TECHNIQUES TECHNICAL CHARACTERISTICS

<b>Dimensions:</b> <b>Dimensions:</b>	Ø170mm x 236mm Ø6.7In x 9.3in
<b>Position de fonctionnement:</b> <b>Operating position:</b>	Verticale, hauteur maximale 8m, Vertical, maximum height 26.24Ft
<b>Poids:</b> <b>Weight:</b>	<b>1.5 Kg</b> 3.31 lb
<b>Classe électrique / Electric class :</b>	I
<b>Frequence / Frequency :</b>	50/60Hz (LED)

# MAINTENANCE MAINTENANCE

## Nettoyage du verre Glass cleaning

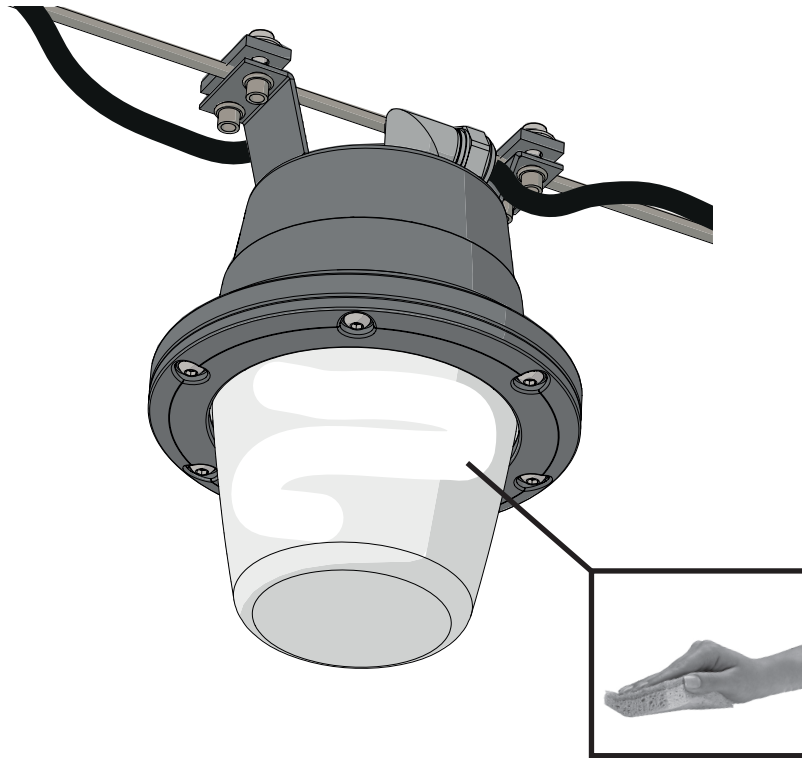

## Vérifications des serrages Tightening checks



### ATTENTION / WARNING

**RISQUE DE DEFAUT D'ETANCHEITE AU SERRAGE**  
**WATERTIGHTENING FAILURE RISK WHEN TIGHTENING**  
Maintenir la base des presses étoupes au serrage de leurs têtes.  
Maintain still the cable glands bases when tightening their heads.

