

Position de fonctionnement: Horizontale

Operating position: Horizontal

Si le câble extérieur, la source lumineuse ou le driver contenus dans ce luminaire sont endommagés, ils doivent être exclusivement remplacés par le fabricant, son agent de maintenance ou une personne de qualification équivalente, cela afin d'éviter tout risque



If the external cable, lighting source or driver contained in this light are damaged, they have to be replaced by the manufacturer or its maintenance agent or an equally qualified worker, in order to avoid any risk

Dimensions

	Karo 900	Karo LINE 900	Karo 1200	Karo LINE 1200
Masse (kg) Weight	7	9	9	10

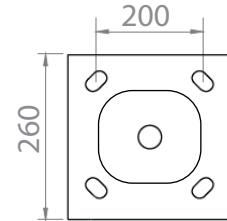

4 Tiges M14/Ø16x300 (En option)
4 anchor bolts M14/Ø16x300 (Optional)

1200

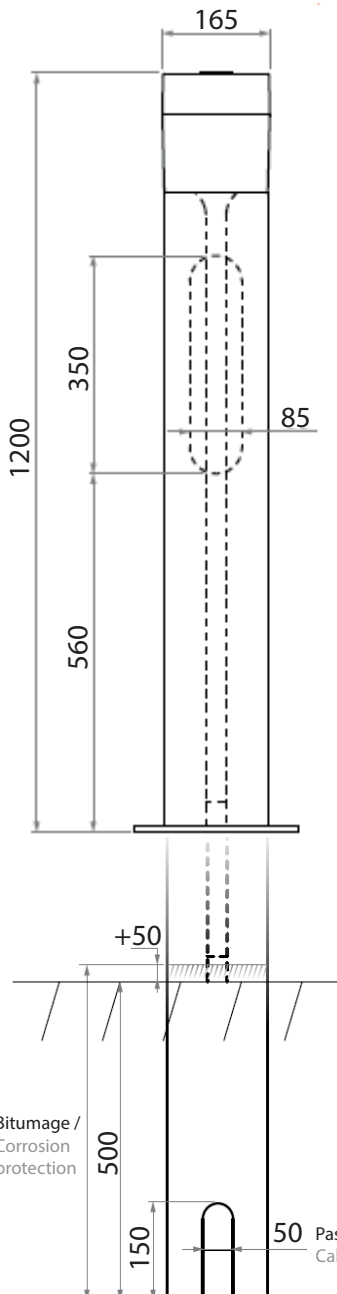

900

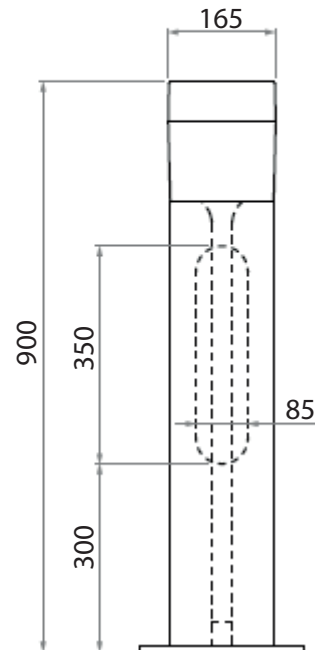

Installation

1

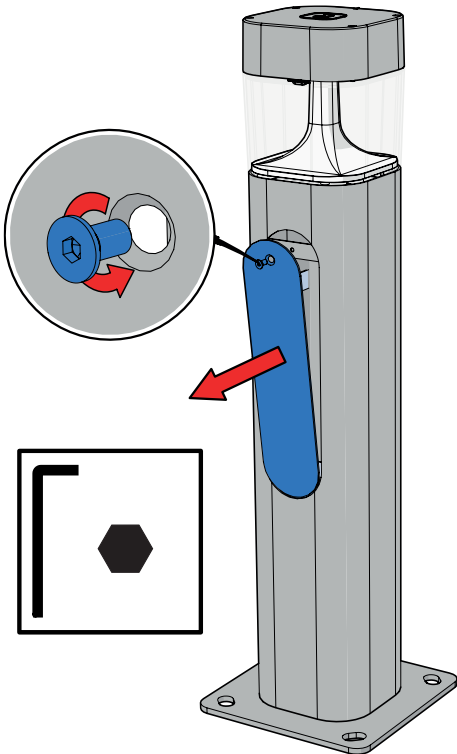

2

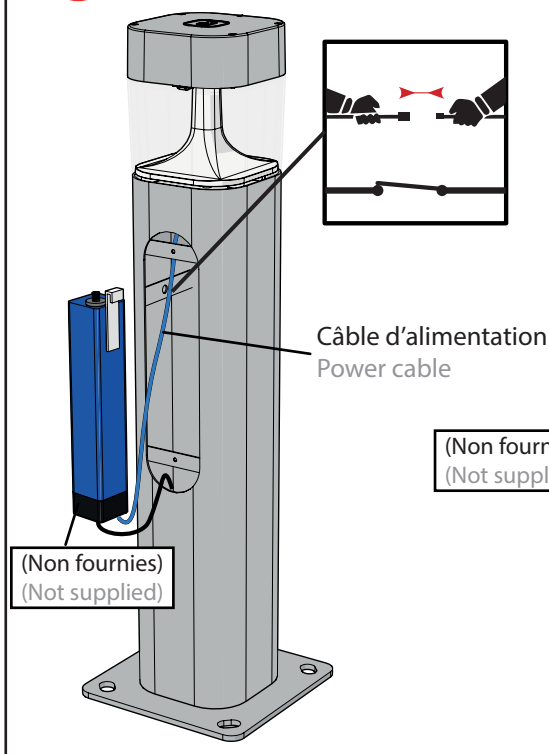

Option

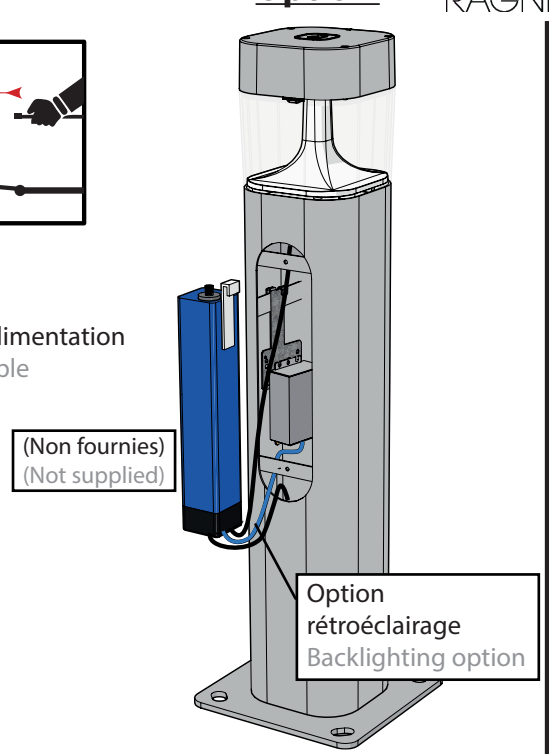

3

Fermer le luminaire en faisant toutes les opérations précédentes dans le sens inverse.
Put the system back by making all the previous operations in the reverse order.

Maintenance

1

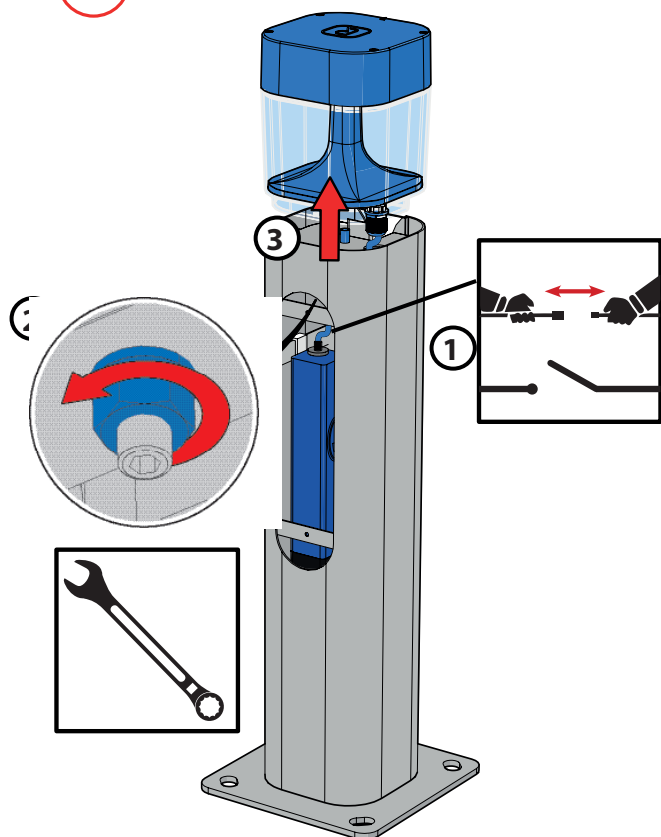

Option rétroéclairage
Backlighting option

1

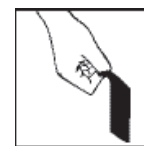
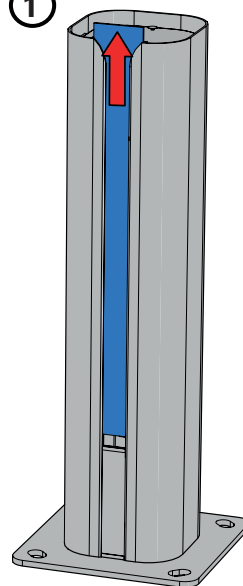

Bandeau LED
LED strip

2

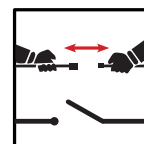

2

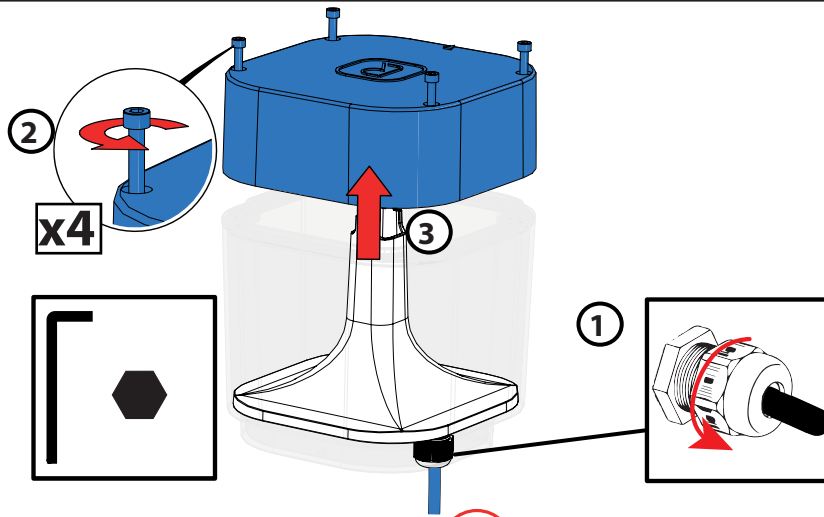

3

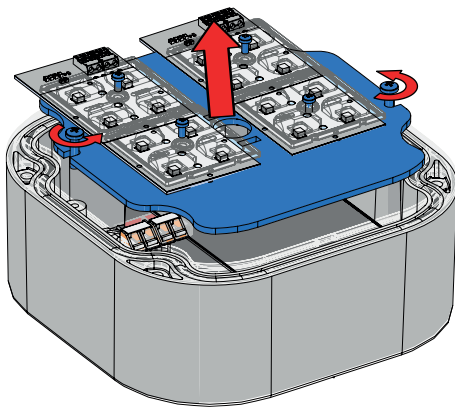

4

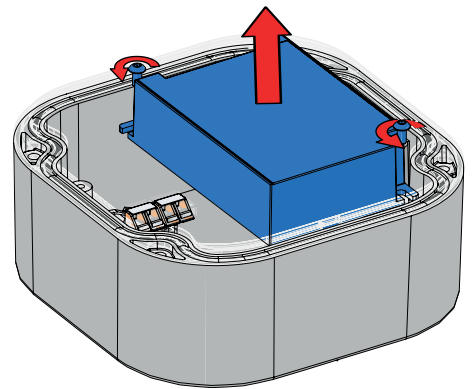
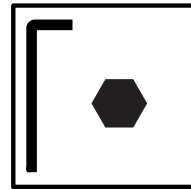
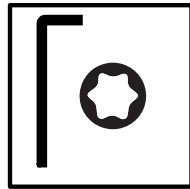

5

Remonter le dôme sur la vasque en effectuant l'étape 2 dans le sens inverse
Reassemble the dome on the basin by making step 2 in the reverse order.

6

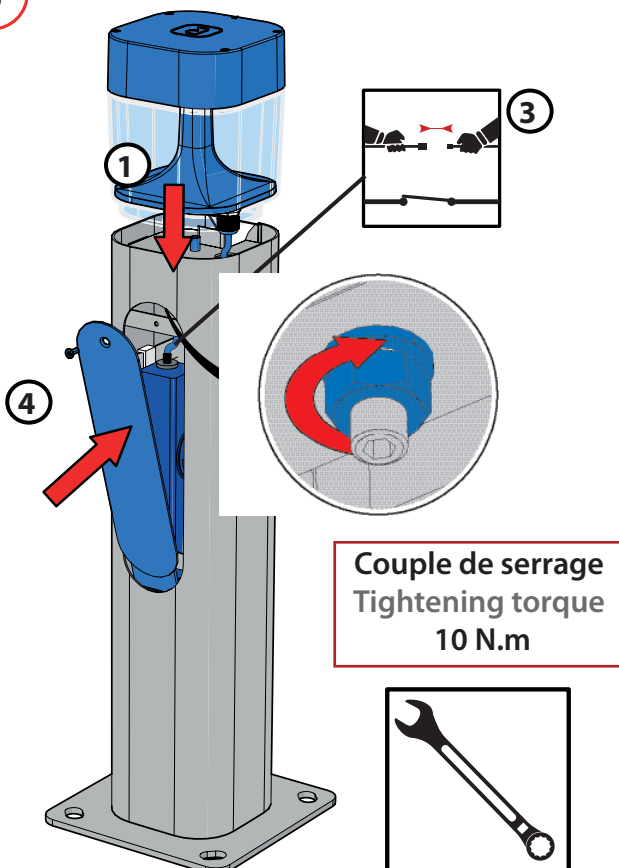

Nettoyage/ Cleaning

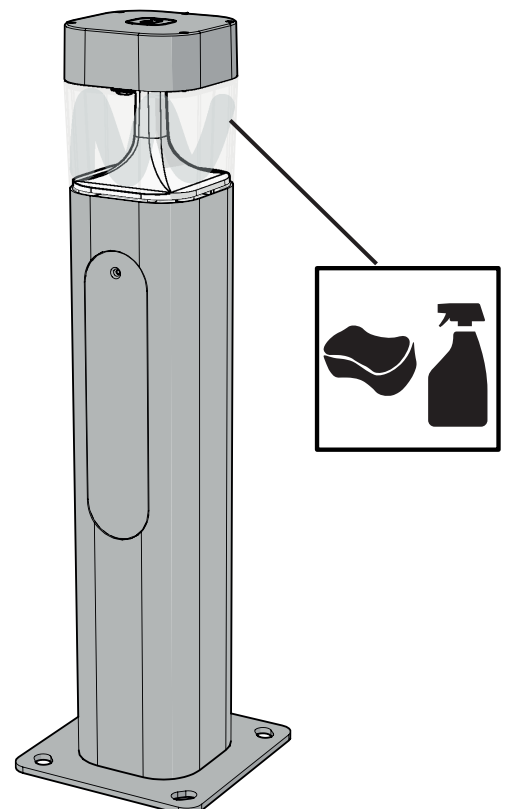

Connexion pour les luminaires précablés

Connection for luminaires with outgoing cable

Les connexions électriques du bloc de jonction doivent respecter la même classe d'isolation que le luminaire.

Electrical connections of the junction box have to main the same insulation class the luminaire.

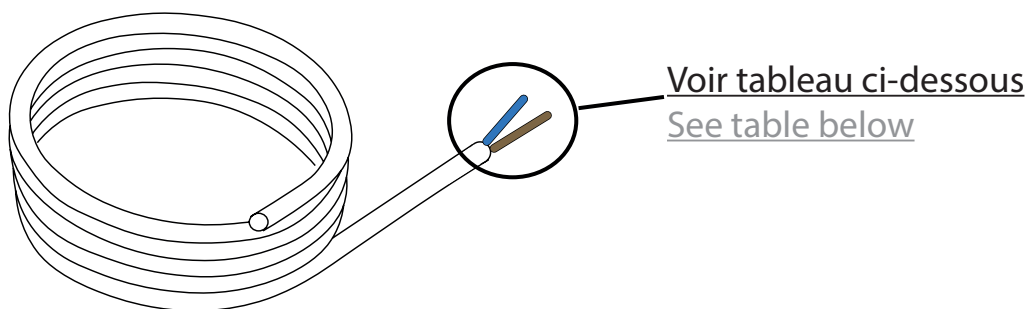

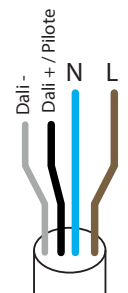
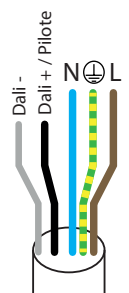
Tension assignée Nominal voltage	220-240V Uniquement pour luminaires avec drivers Only for luminaires with drivers	
Nombre de bornes et capacité de connexion assigné Number of poles and terminal section	<u>CLII-DALI</u> 4x 1.5mm² 	<u>CLI-DALI</u> 5G 1.5mm² 
Méthode de fixation Fixation method	Dépend du bloc de jonction Depend on the junction box	