

R-light

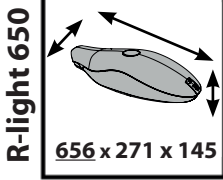
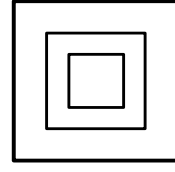
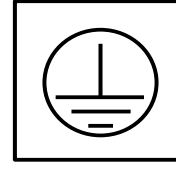
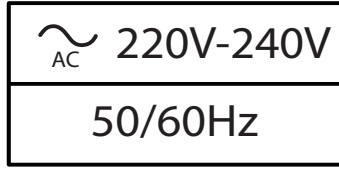
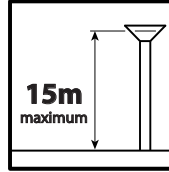
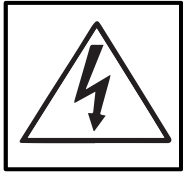

Position de fonctionnement: Horizontale Operating position: Horizontal

La source lumineuse ou le driver contenu dans ce luminaire ne doit être remplacé que par le fabricant, son agent de maintenance ou une personne de qualification équivalente.

The light source or driver contained in this light should only be replaced by the manufacturer, its service agent or an person of equivalent qualification.

Installation

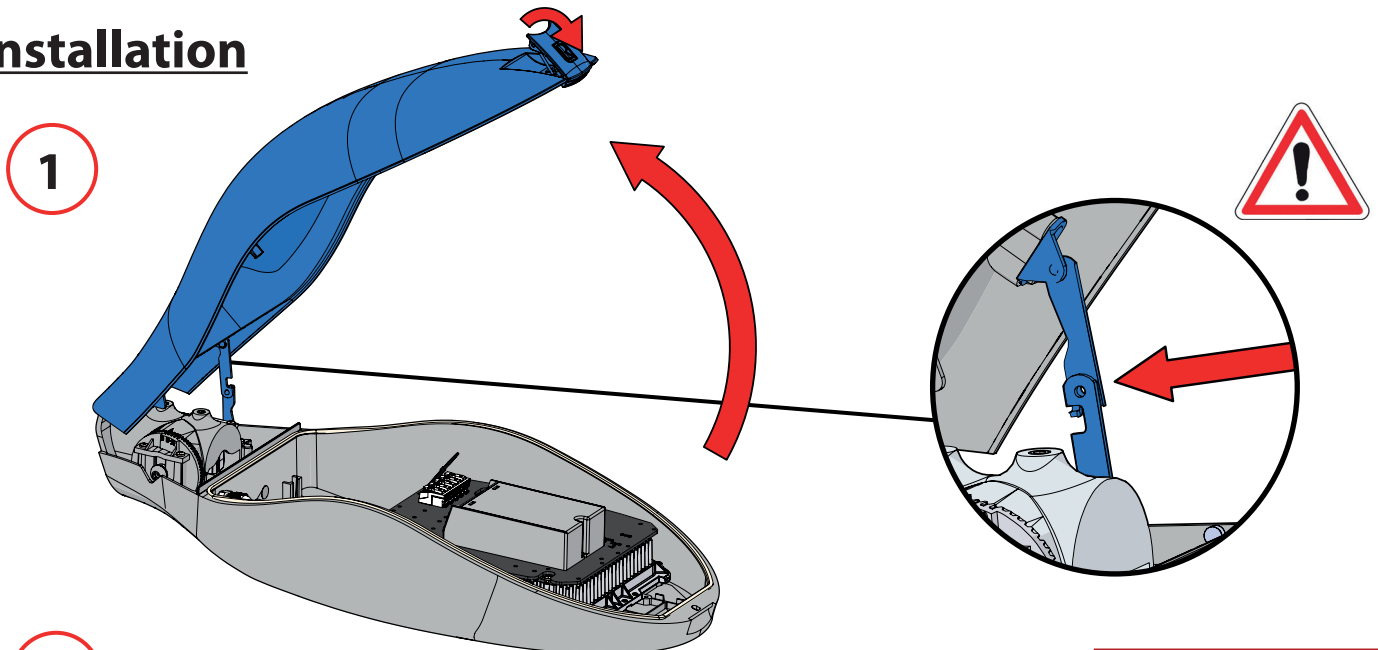

Couple de serrage
Tightening torque
15 N.m

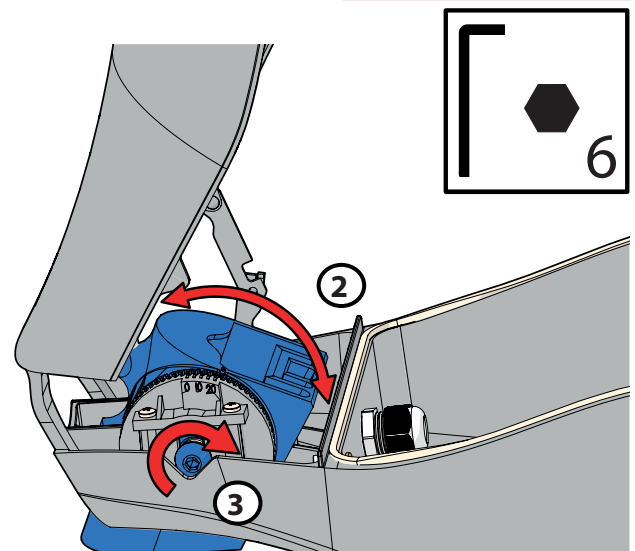
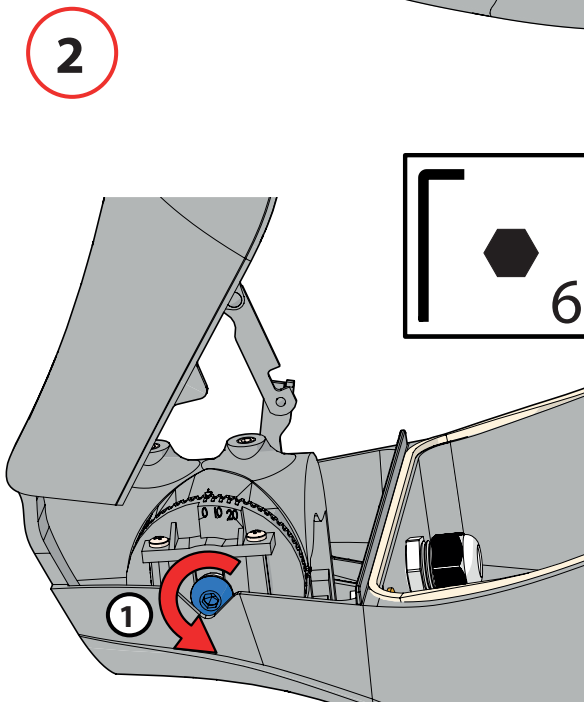

3

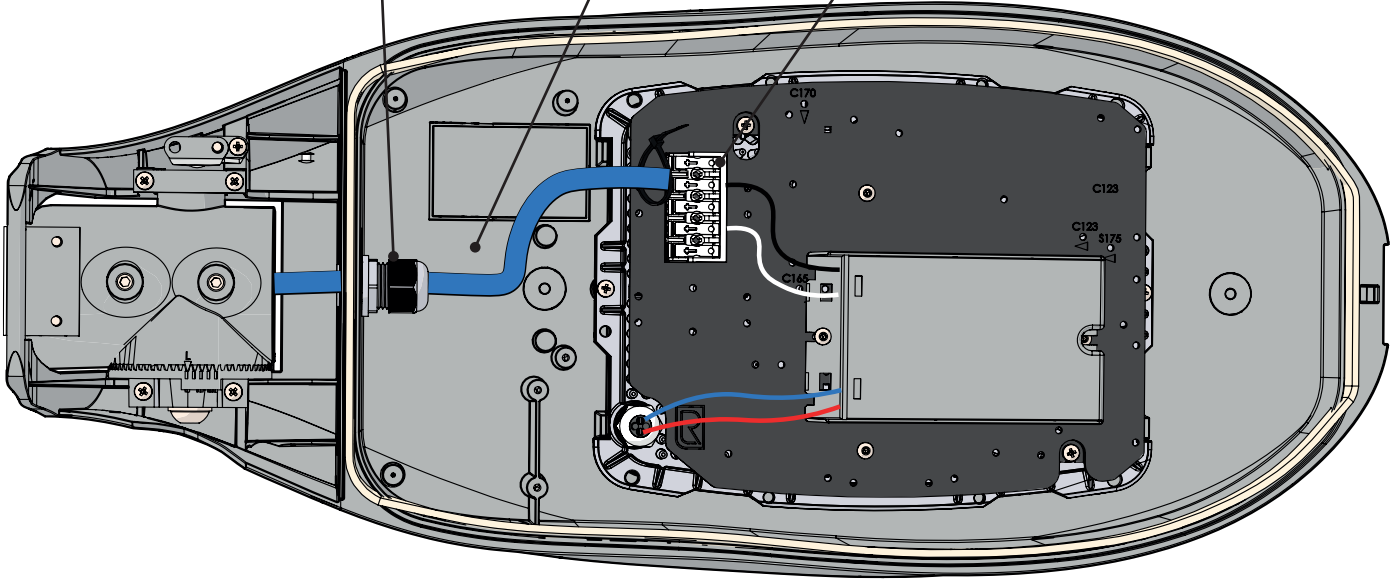
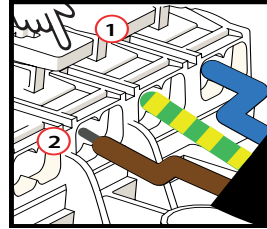
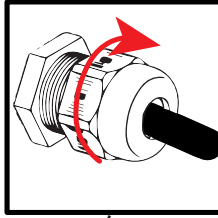
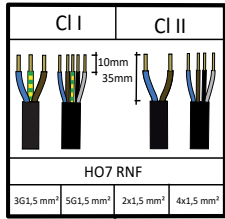

4

Fermer le luminaire en faisant toutes les opérations précédentes dans le sens inverse.
Put the system back by making all the previous operations in the reverse order.

5

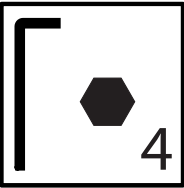
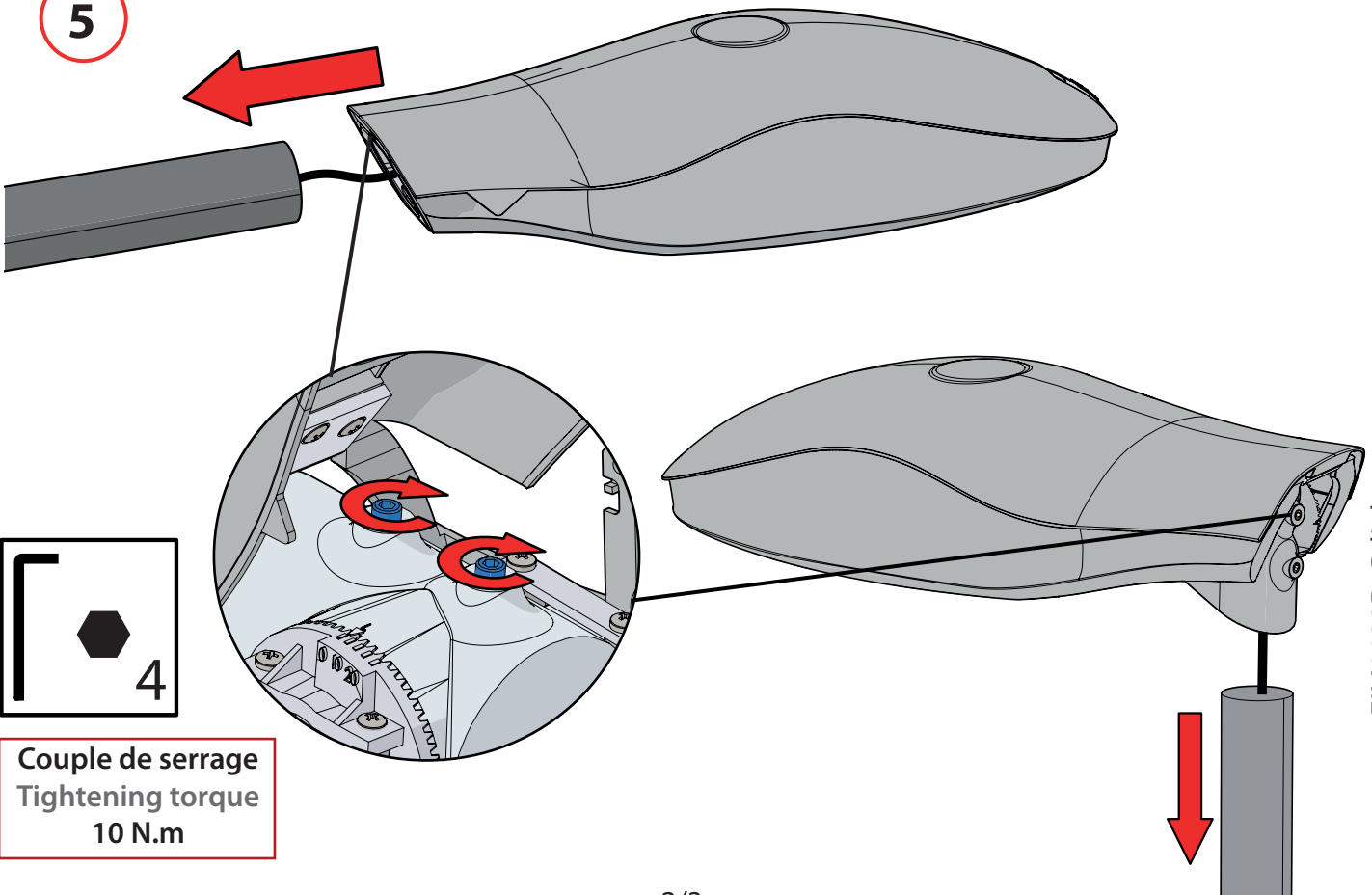

Couple de serrage
Tightening torque
10 N.m

Maintenance

1

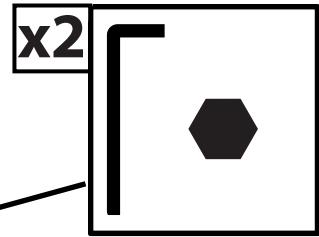
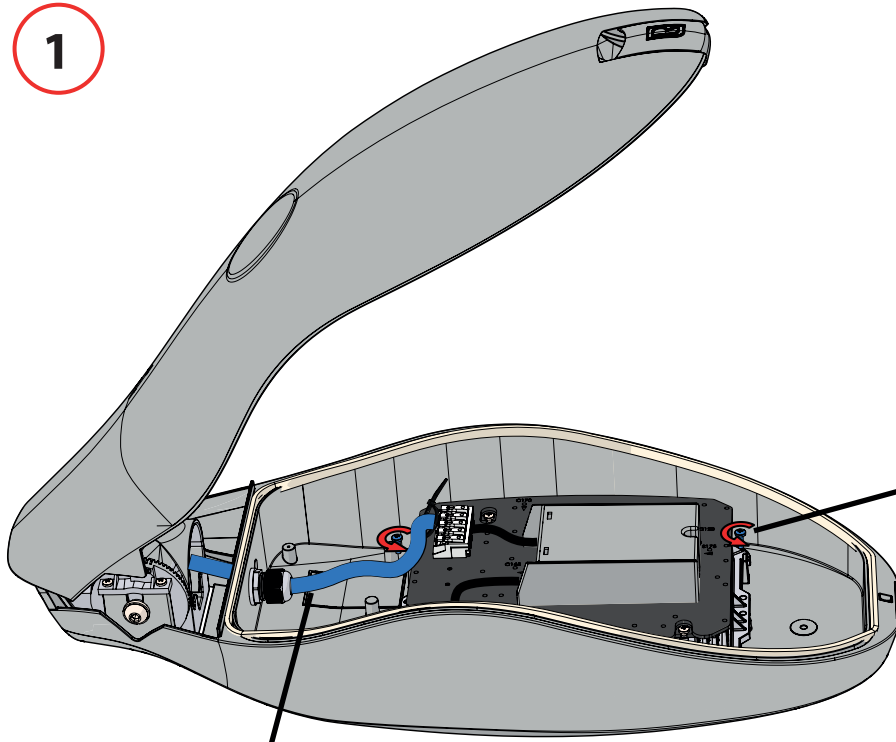

2

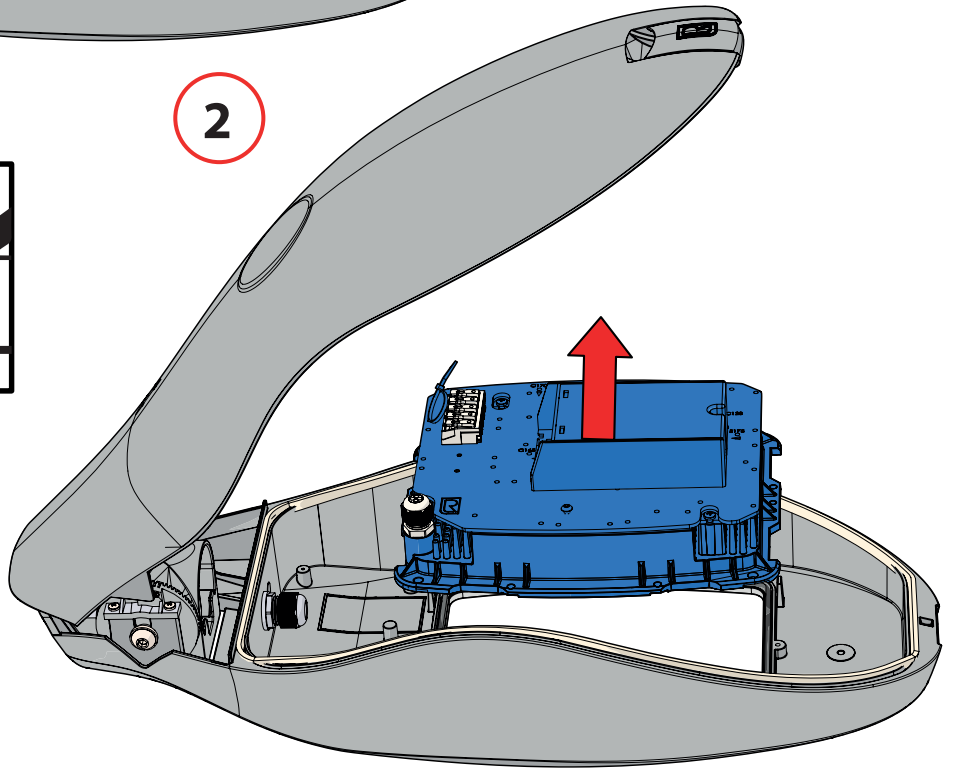
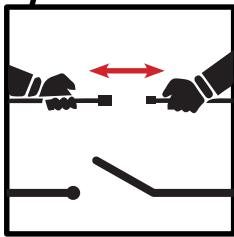

Nettoyage / Cleaning

